

Instruction Manual

BUILD IN GAS OVEN

UBGMMT60SS

UBGMMT60GF

General Instruction

These instructions are only valid if the country symbol appears on the appliance. If the symbol does not appear on the appliance, it is necessary to refer to the technical instructions which will provide the necessary instructions concerning modification of the appliance to the conditions of us of the country.

Warning:

- a) **The use of a gas cooking appliance results in the production of heat and moisture in the room in which it is installed. Ensure that the kitchen is well ventilated: keep natural ventilation holes open or install a mechanical ventilation device (mechanical extractor hood)**
- b) **During use the appliances becomes hot. Care should be taken to avoid touching heating elements inside the oven**
- c) **Accessible parts may become hot during use. Young children should be kept away.**
- d) **Do not use harsh abrasive cleaners or sharp metal scrapers to clean the oven door glass since they can scratch the surface, which may result in shattering of the glass.**
- e) **If the supply cord is damaged, it must be replaced by the manufacturer, its service agent or similarly qualified persons to avoid a hazard.**
- f) **The appliance is not intended for use by persons (including children) with reduced physical, sensory or mental capabilities, or lack of experience and knowledge, unless they have been given supervision or instruction**
- g) **Children should be supervised to ensure that they do not play with the appliance**
- h) **Children less than 8 years of age shall be kept away unless continuously supervised.**
- i) **This appliance can be used by children aged from 8 years and above and**

persons with reduced physical, sensory or mental capabilities or lack of experience and knowledge if they have been given supervision or instruction concerning use of the appliance in a safe way and understand the hazards involved. Children shall not play with the appliance. Cleaning and user maintenance shall not be made by children without supervision

- j) Ensure that the appliance is switched off before replacing the lamp to avoid the possibility of electric shock.

Close-Up View

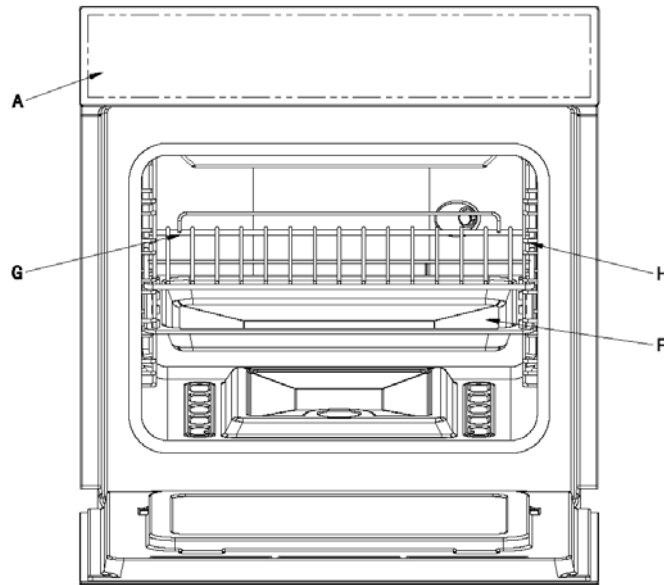

UBGMMT60SS
UBGMMT60GF



- | | |
|---|---|
| A. Control Panel | G. Oven Rack |
| B. Oven/roast/grill knob | H. Guides for sliding the racks or dripping pan in or out |
| C. Oven Light button | I. Valve knob for gas oven |
| D. Timer Knob (only available on some models) | J. Electric cooker clock Knob |
| E. Oven indicator light | K. Switch Knob |
| F. Dripping Pan or Baking Sheet | M. Convection fan Switch |

How to use your oven

The various features of this oven are controlled via the knobs and buttons located on the control panels.

Notices: The first time you use your appliance, we recommend that you set the thermostat to the highest setting and leave the oven on for about half an hour with nothing in it, with the oven door shut. Then, open the oven door and let the room air. The door that is often detected during this initial use is due to the evaporation

of substances used to protect the oven during storage and until it is installed.

Notices: Place the dripping pan provided on the bottom shelf of the oven to prevent any sauce and/or grease from dripping onto the bottom of the oven only when grilling food or when using the rotisserie (only available on certain models). For all other types of cooking, never use

the bottom shelf and never place anything on the bottom of the oven when it is in operation because this could damage the enamel. Always place your cookware (dishes, aluminum foil, etc) on the grid provided with the appliances inserted especially along the oven guides.

The oven knob (B)

This knob is used not only to select the different oven modes, but also to choose the right cooking temperature from among the temperatures shown on the knob itself. (from 140 to 240) for the food to be cooked in the oven. The electronic ignition device of the oven is build into the control knob itself. To light the oven burner, press the oven knob “B” in all the way and turn it anti-clockwise, setting it to the **Max position (keeping the oven door shut)**. **Since the oven is equipped with a safety device, after lighting the burner keep knob “B” pressed in for about 6 seconds to allow the gas to pass until the safety thermocouple is heated. The electronic ignition device of the oven burner must not be activated for more than 15 seconds. If the burner fails to light after 15 seconds, stop pressing knob “B”, open the oven door and wait for at least one minute before your try to light the burner again.** The cooking temperature is selected by matching the desired temperature with the reference mark on the control panel; the complete range of temperatures is shown below:

The oven will automatically reach the temperature set, and the thermostat, which is controlled by the knob, will keep it constant.

Lighting the oven manually

In the event of a brief power failure, the oven burner can be lit by hand:

- a) open the oven door
- b) hold a match or lighter near the burner hold as shown in the figure, press knob “B”, in fully and turn it anticlockwise, setting it to the Max position. Since the oven is equipped with a safety device, after lighting the burner keep knob “B” pressed in for about 6 seconds to allow the gas to pass until the safety thermocouple is heated.

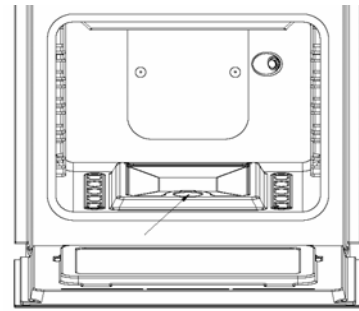

- c) Once the burner is lit, shut the oven door.

Importance Notice: should the burner flame accidentally go out, turn control knob “B” to the off position, open the oven door and wait for at least one minute before trying to light the burner again.

The grill knob (B)

Your oven is equipped with an electrical grill. **The extremely high and direct temperature of the grill makes it possible to brown the surface of meats and roasts while locking in the juices to keep them tender. The grill is also highly recommended for dishes that require a high temperature on the surface: such as beef steaks, veal, rib steak, filets, hamburgers etc...**

Press knob “B” in fully and set it to position the grill (which uses infrared rays) and the rotisserie motor (only available on some models) will come on, the latter will stay on if the grill is in operation.

Important: when using the grill, the oven door must be kept shut; for further details on show to use the rotisserie, please read the corresponding paragraph.

The rotisserie (only available on certain models)

To start the rotisserie, processed as follows:

- a) place the dripping pan on the 1st rack;
- b) insert the special rotisserie support on the 3rd rack and position the spit by inserting it through the special hole into the rotisserie at the back of the oven;
- c) start the rotisserie using knob “B” to select setting

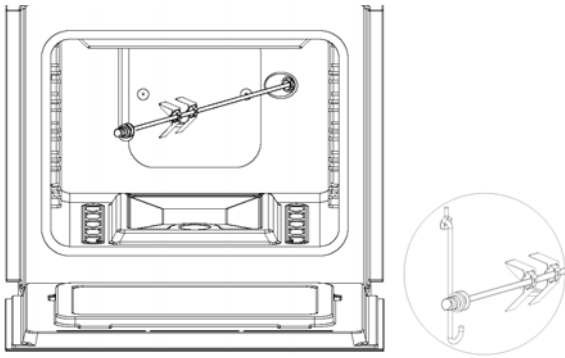

Notice: the oven door gets hot during cooking. Please keep children well away.

The oven light button (C)

This is the button indicated by symbol and allows you to turn the light on inside your oven to supervise cooking without having to open the oven door.

Timer(D) (only available on certain models)

To use the timer, the buzzer “D” must be wound up by turning the knob one full turn clockwise; then turn it back to the desired time so that the number of minutes on the knob matches the reference mark on the panel.

The grill indicator light (E)

This light comes on when the grill starts.

Setting the time of day (only available on some models)

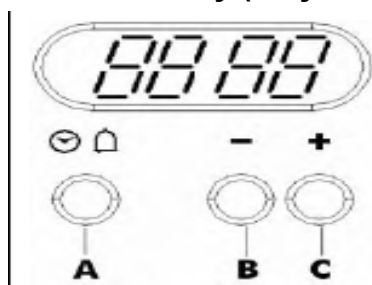

When the oven is switched on for the first time (or if power has been cut to the appliance), three zeros will flash on the timer display.

- To set the time of day, hold down button (A) and then press the(B) and (C) buttons until the current time of day is shown on the timer display.
- The speed that the time adjusts at depends on how hard the (B) and (C) buttons are held down.
- When the correct time of day is shown, release all the buttons. After a few seconds the time of day will be set on the timer display.

Setting a countdown time (GB-56RCD、 EGB-56RCD only)

The valve ignition(I)

This knob is used not only to select the different oven modes, but also to choose the right cooking temperature from among the temperatures shown on the knob itself. (from 130 to 250) for the food to be cooked in the oven. The electronic ignition device of the oven is build into the control knob itself. To light the oven burner, press the oven knob “I” in all the way and turn it, setting it to

the or position, please refer to

Operation for B Knob.

Cooling ventilation

To cool down the temperature of their exterior, some models are equipped with a cooling fan that comes on by turning the selector knob “B”. During cooking, the fan is always on and a normal flow of air can be heard exiting between the oven door and the control panel.

Note: when cooking is done, the fan stays on until the oven cools down sufficiently.

Warning: do not use the oven in the event of a prolonged power failure if the cooling fan does not work.

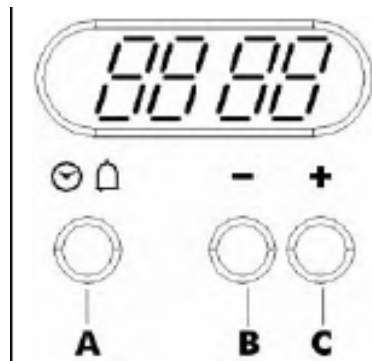

- O Press button (C) and the numbers on the timer display will begin to advance and a symbol will illuminate.
- O Use buttons (B) and (C) to adjust the time on the timer display, until it shows the length of time that you want the oven to countdown for.
- O The maximum countdown time that can be set is 99 minutes and 59 seconds.
- O Once your desired countdown time is displayed, release all the buttons. After 10 seconds, the countdown time will be stored and the countdown will commence immediately.
- O At the end of the cooking time a bell will ring for 7 minutes. It can be switched off by pressing button (C) once.
- O To reset a countdown before it reaches its end time, press buttons (B) and (C) simultaneously. Then release button (C) first, followed by button (B).

IMPORTANT: If you have the oven or grill in use whilst the timer is counting down. When the countdown ends, the oven will continue to heat. You must turn off the oven/grill using the oven function and temperature control knob.

Adjusting the audible signal (GB-56RCD, EGB-56RCD only)

There are 3 levels of audible signal available; to adjust it you should do the following:

- O When the time of day is shown on the timer display, press button (B) for approximately 2 seconds. You will then hear the current level of audible signal.
- O Repeat this process until the audible signal reaches the level that you require, and then release the button (B).

Using the minute minder

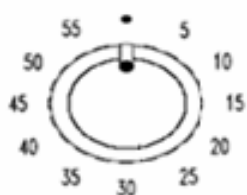

- The minute minder can be used independently of an oven cooking function for a period of up to 60 minutes.
- O To set the timer, turn the knob fully clockwise until it stops and then turn it back anticlockwise to the required time.
 - O The period that has been set will expire when the control knob reaches zero, a brief audible signal will sound.

IMPORTANT: If you have the oven or grill in use whilst the timer is counting down. When

the countdown ends, the oven will continue to heat. You must turn off the oven/grill using the oven function and temperature control knob.

How to remove the oven door

For a more thorough clean, you can remove the oven door. Proceed as follows:

- a) open the door fully
- b) lift and turn the small levers situated on the two hinges;
- c) grip the door on the two external sides, shut it slowly but not completely;
- d) pull the door towards you, pulling it out of its seat;

Reassemble the door by following the above procedures backwards.

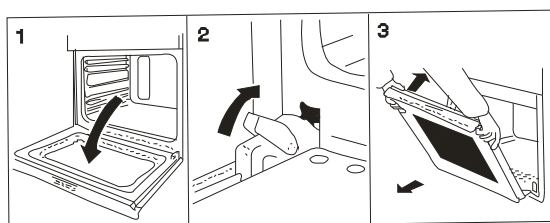

Replacing the oven lamp

- a) Disconnect the oven from the power supply by means of the unipolar switch used to connect the appliance to the electrical mains; or unplug the appliance if the plug is

accessible;

- b) Remove the glass cover of the lamp-holder
- c) Remove the lamp and replace with a lamp resistant to high temperature (300) with the following characteristics:
 - Voltage: 230/240V
 - Wattage: 15W
 - Type E14
- d) Replace the glass cover and reconnect the oven to the mains power supply.

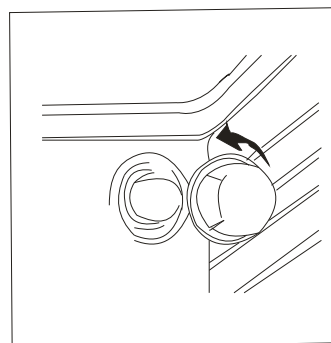

Practical Cooking Advice

The oven offers a wide range of alternatives which allow you to cook any type of food in the best possible way with time you will learn to make the best use of this versatile cooking appliance and the following directions are only a guideline which may be varied per your own personal experience

Baking Cakes

When baking cakes always place them in the oven after it has been preheated (about 15 minutes) The temperature is normally around 160°C. Do not open the door while the cake is baking to prevent it from dropping, in general:

Pastry is too dry

Increase the temperature by 10°C and reduce the time.

Pastry dropped

Use less liquid or lower the temperature by 10°C.

Pastry is too dark on top

Place it on a lower rack, lower increase the cooking time.

Cooked well on the inside but sticky on the outside
Use less liquid, lower the tempera, tore, and increase the cooking time.

The pastry sticks to the pan
Grease the pan well and sprinkle it with a dusting of flour or use greaseproof paper.

Cooking Pizza

For tasty crispy pizzas:

Preheat the oven for at least 15 minutes

Use a light aluminum pizza pan, placing it on the rack supplied with the oven. If the dripping pan is used, this will extend the cooking time, making it difficult to get a crispy crust;

Do not open the oven door frequently while the pizza is cooking;

If the pizza has a lot of toppings (three or four), recommend you add the mozzarella cheese on halfway through the cooking process.

Cooking Fish and Meat

When cooking white meat. fowl and fish, use temperature settings from 170 ~C to 190 C.

For red meat that should be well done on the outside while tender and juicy in the inside, it is a good idea to

start with a high temperature setting (200'C-220'C) for a short time, then turn the oven down afterwards.

In general, the larger the roast, the lower the temperature setting. Place tile meat on the centre of the grid and place the dripping pan beneath it to catch the fat.

Make sure that the grid is inserted so that it is in the center of the oven. If you would like to increase the amount of room below, use the low rack. For savory (especially duck and wild game), dress the meat lard or bacon on the top.

Using the Grill

Important: always use the grill with the oven door shut. This will allow you both to obtain excellent results and 10 save on energy (approximately 10%)

Use the R "grill" mode. placing the food under the centre of the grill.

Therefore, the best results when using the grill modes are obtained by placing the grid on the lower racks (see cooking table) then, to prevent fat and grease from dripping onto the bottom of the oven and smoke from forming, place a dripping-pan on the 1st oven rack from the bottom.

Selecto r	Food to be cooked	Weight (in kg)	Cooking rack position from oven	Preheatin g time (minutes)	Thermostat knob setting	Cooking time [minutes)
Oven	Lasagna	2,5	3	10	200	55-60
	Cannelloni	2,5	3	10	200	40-45
	Pasta bakes	2,2	3	10	200	50-55
	Veal	1,7	2	10	210	80-90
	Chicken	1,5	3	10	200	70-80
	Turkey roll	2,5	3	10	200	80-90
	Duck	1,8	3	10	200	90-100
	Rabbit	2,0	3	10	200	80 -90
	Leg of lamb	1,5	3	10	200	70-80

	Mackerels	1,8	3	10	200	80-90
	Trout baked in	1,5	3	10	180	30-40
	Neapolitan-style pizza	1,0	3	10	200	30-35
	Dry biscuits	0,6	3	15	210	15-20
	Tart	0,5	4	15	180	25-30
	Chocolate cake	1,1	3	15	180	30-35
	Leavened cakes	1,0	3	15	165	50-60
		1,0	4	15	165	50-60
	Soles and cuttlefish	1	4	5	-	6
	Squid and prawn kebabs	1	4	3	-	4
	Cod filet	1	4	3	-	10
	I Grilled vegetables	1	4	-	-	8-10
	Veal steak	1	4	5	-	20-25
	Chops	1,5	4	5	-	20-25
	Hamburgers	1	4	3	-	10-15
	Sausages	1,7	4	5	-	20-25
	Toasted sandwiches	n. ⁰⁴	4	3	-	2-3
Grill	With rotisserie (where present)					
	Veal on the spit	1,0	-	-	-	80-90
	Chicken on the spit	1,5	-	-	-	80-90
	Lamb on the spit	1,0	-	-	-	80-90

Note: cooking times are approximate and may vary per personal taste When cooking using the grill, the dripping pan must always be placed on the 1st oven rack from the bottom.

Installation

The appliance must be installed only by a qualified person in compliance with instructions provided. The manufacturer declines all responsibility for improper installation which may harm persons and animals and damage property.

Important: The power supply to the appliance must be cut off before any adjustments or maintenance work is done on it.

Positioning:

Important: this appliance may be installed and used only in permanently ventilated rooms in compliance with current National Norms. The following requirements must be observed.

- The room must be equipped with an exhaust system that vents the combustion fumes to the outside. It may consist of a hood or and electric fan that automatically starts each time the appliance is turned on.

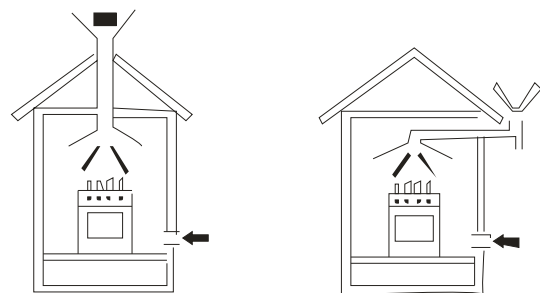

A flue or branched flue system directly (only for cooking appliances) to the Outside

- The room must also have a system that allows for normally. The flow of air needed for combustion must not be less than 2 m³/h per KW of installed power. The air circulation system may take air directly form the outside by means of a pipe with an inner cross section of at least 100 cm²; the

opening cannot under any circumstances be blocked accidentally (Fig A), The system can also provide the air needed for combustion by indirect means. i.e. form adjacent rooms fitted with air circulation tubes as described above. However, these rooms must be common rooms, bedrooms or rooms with a fire hazard (Fig. B)

Details A Adjacent Room

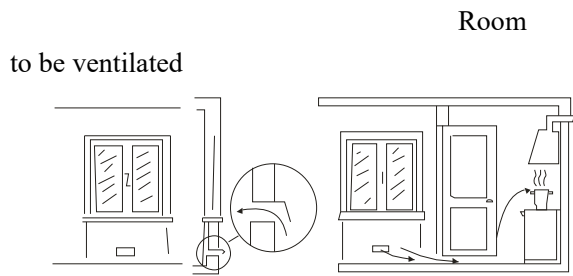

Fig A Examples of Ventilation Opening Increasing opening For combustion air between door and floor

c) Liquefied petroleum gas is heavier than air and, therefore, settles downwards. Thus, rooms containing LPG cylinders must also be equipped with apertures to the outside for ventilation of gas in the event of leaks. LPG cylinders must not, therefore, be installed or stored in rooms or storage areas that are below ground level (cellars, etc.) whether they are partially or completely full. It is a good idea to keep only the cylinder being used in the room, positioned so that it is not subject to heat produced by external sources (ovens, fireplaces, stoves, etc.) which could raise the temperature of the cylinder to the above 50.

Prior to installation, ensure that the local distribution conditions (nature of the gas and gas pressure), and the adjustment of the appliance are compatible. The adjustment conditions for this appliance are stated on the label (or data plate) This appliance is not connected to a combustion products evacuation device. It shall be installed and connected in accordance with current installation regulations. Attention shall be given to the relevant requirement regarding ventilation.

Installation of Build-in Ovens

To ensure that build-in appliance functions properly, the cabinet containing it must be appropriate. The figure below gives the dimensions of the cut-out for installation under the counter or in a wall cabinet unit.

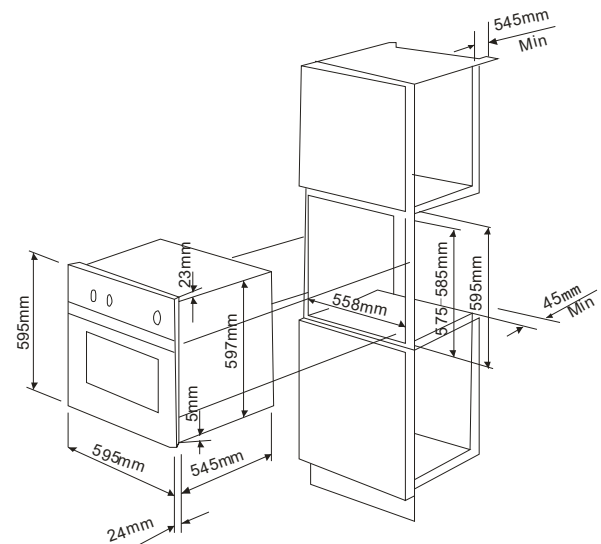
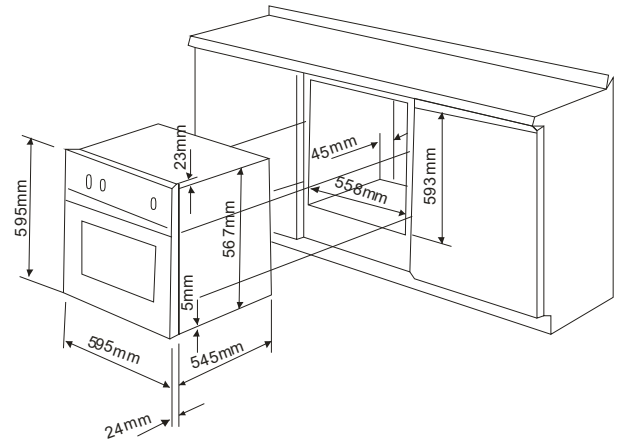

To ensure adequate ventilation, the back panel of the cabinet unit must be removed. Installing the oven so that it rests on two strips of wood is preferable. If the oven rests on a continuous, flat surface, there must an aperture of at least 45*560mm.

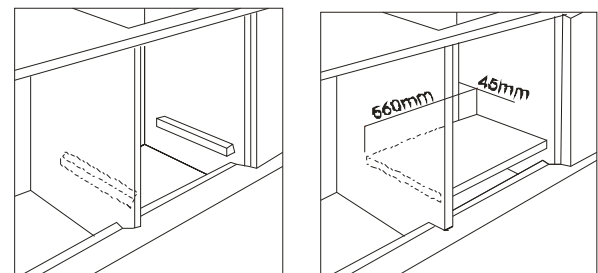

The panels of the adjacent cabinets must be made of heat resistant material. Cabinets with a veneer

exterior must be assembled with glues with glues which can withstand temperature of up to 100.

In compliance with current safety standards, contact with the electrical parts of the oven must not be possible once it has been installed.

To fasten the oven to the cabinet, open the door of the oven and attach it by inserting the 4 wooden screws into the 4 holes located on the perimeter of the frame.

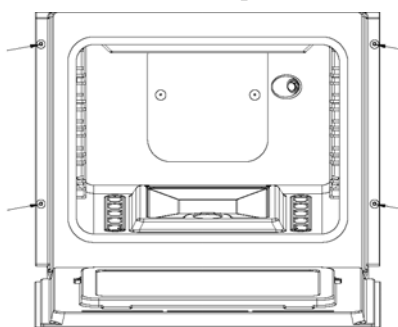

Electrical Connection

Those ovens equipped with a three-pole power supply cable are designed to operate with alternating current with the voltage and frequency indicated on the data plate (located on the appliance) and in the instruction manual. The wire for earthing the appliance is yellow-green in color.

Fitting on a power supply cable

Opening the terminal board:

- Using a screwdriver, pry on the side tabs of the terminal board cover;
- Pull open the cover of the terminal board

To install the cable, proceed as follows:

- Remove the wire clamp screw and the three contact screws L-N
- Fasten the wires beneath the screw heads using the following color scheme; **Blue(N)** Brown(L), **Yellow- Green**
- Fasten the supply cable in place with the clamp and close the cover of the terminal board.

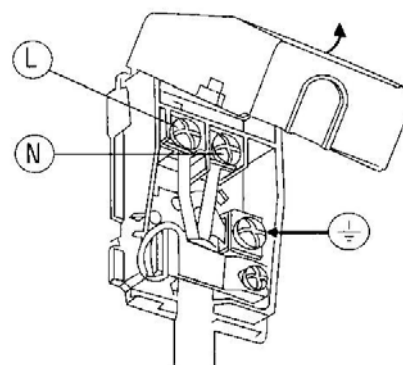
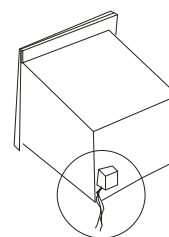

Connecting the supply cable to the mains

Install a standardized plug corresponding to the load indicated on the data plate. When connecting the cable directly to the mains, install a unipolar circuit-breaker with a minimum contact opening of 3 mm between the appliance and the mains. The unipolar circuit breaker should be sized per the load and should comply with current regulations (the earth wire should not be interrupted by circuit breaker).

The supply cable should be positioned so that it does not reach a temperature of more than 50 with respect to the room temperature, anywhere along its length.

Before making the connection, check that:

- the electrical safety of this appliance can only be guaranteed if the cooker is correctly and efficiently earthed, ways ensure that the earthing is efficient; if you have any doubts call in a qualified technician to check the system. The manufacturer declines all responsibility for damage resulting from a system which has not been earthed.
- Before plugging the appliance into the mains, check that the specifications indicated on the date plate (on the appliance and/or packaging) correspond to those of the electrical mains system of your home.
- Check that the electrical capacity of the system and sockets will support the maximum power of

Adjust the screw located outside the thermostat cock pin until the flame is small but steady (the flame can be seen through the slots on the oven bottom)

N.B.: In this case of liquid gas, the regulation screw must be screwed in all the way.

Check that the burner does not turn off when you turn the knob from **Max** to Min quickly and when you open and close the oven door quickly.

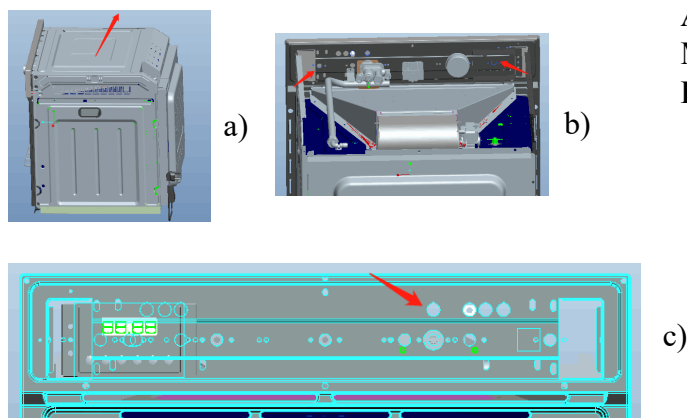

Warning

On completion of this operation, replace the old rating sticker with one indicating the new type of gas used. This sticker is available from our Service Centers.

Note Should the pressure of the gas used to be different (or vary) from the recommended pressure, it is necessary to fit a suitable pressure regulator onto the inlet pipe (in compliance with the current National Norms regarding “regulators for channeled gas”

All gas regulation and conversion procedures MUST be carried out by a qualified Gas Safe Registered engineer!

Technical Specifications

Inner dimensions of the oven:

Width:43.6cm

Depth41cm

Height31.5cm

Overall dimensions for oven volume: 56liters

This appliance conforms with the following

European economic community directives:

-73/23/EEC of 19/02/73(low voltage) and subsequent modifications;

-89/336/EEC of 03/05/89/ (electromagnetic compatibility) and subsequent modifications;

-90/336/EEC of 29/06/90(gas) and subsequent modifications;

93/68/EEC of 22/07/93 and subsequent modifications;

Burner and Nozzle Characteristics

		Liquid gas				Natural gas				Electric part			
		Nozzle 1/100 mm		Flow kW g/h		Supply Pressure s mbar	Nozzle 1/100 mm		Flow kW g/h		Supply Pressur es mbar	Vol tag e fre	Po wer (W)
Top	Botto	Top	Bott	Top	Botto		Top	Botto	Top	Botto			

		m		om			m		m		que ncy	
GB-56 RC (GB-5 6RCD	0.6 5	0.8	1.81k W 132 g/h	2.59 kW 188 g/h	29	0.85	1.1	1.3k W 95 g/h	2.1 kW 153 g/h	20	220 -24 0V ~ 50- 60 Hz	40
EGB-5 6RC (EGB-5 6ERC , EGB-5 6RCD	-	0.76	-	2.16 kW 158 g/h	29	-	1.05	-	2.0 kW 145 g/h	20	220 -24 0V ~ 50- 60 Hz	2240

* At 15°C and 1013 mbar-dry gas

** Propane Gross Heat Value = 50.37MJ/Kg

*** Butane Gross Heat Value = 49.47MJ/Kg

Natural Gross Heat Value = 37.78MJ/Kg

Methane Gross Heat Value = 15.87MJ/Kg