

ICONDD75FZ

EN Operating and maintenance instructions



ASSEMBLY INSOLE

60817495 - 29/05/18

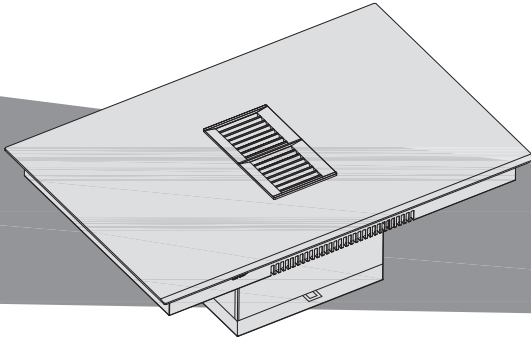
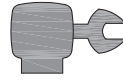

a1  x 2



a2  x 1



a3  x 1



a4  x 1



a5  x 1

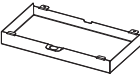

a6  x 1



a7  x 1



a8  x 2



a9  x 1



a10  x 2



Ø3.5 x 9,5

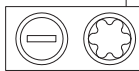
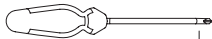

T15

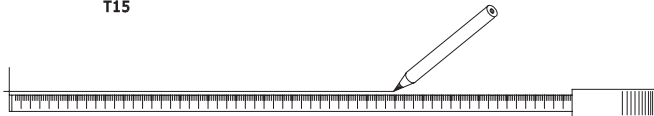
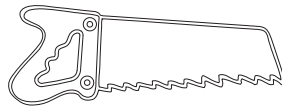

180x90

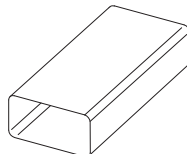

P1

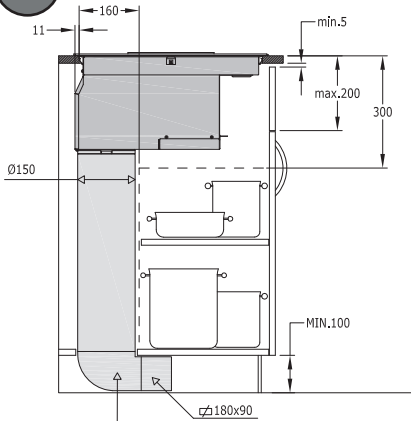

Ø150 ▶ 90° ▶ 180x90

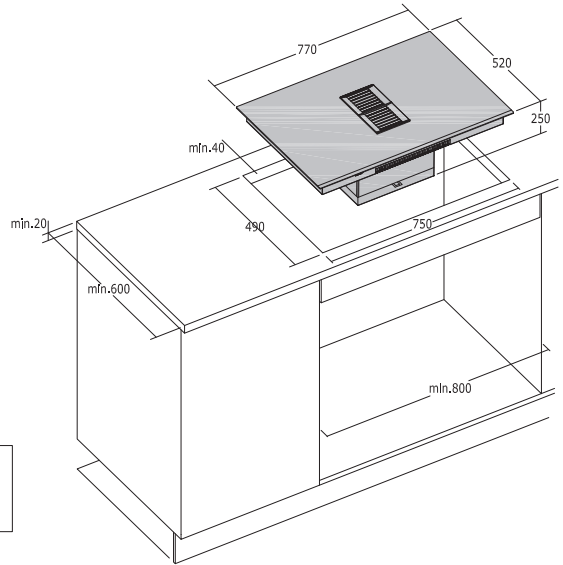

P2

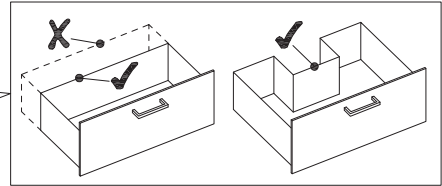
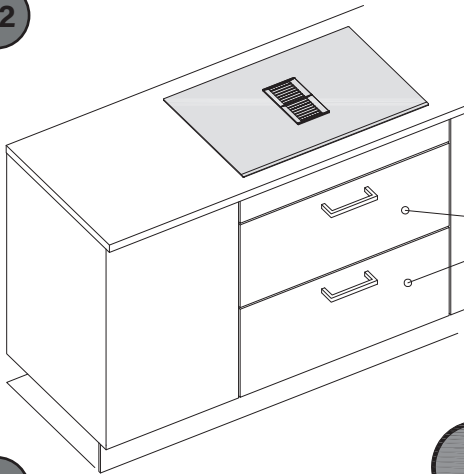

P3

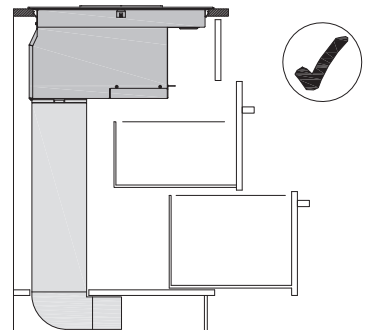
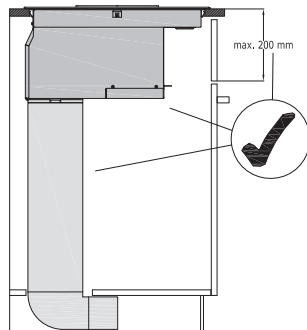
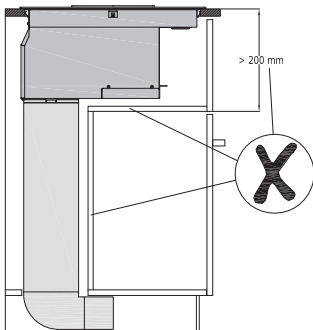

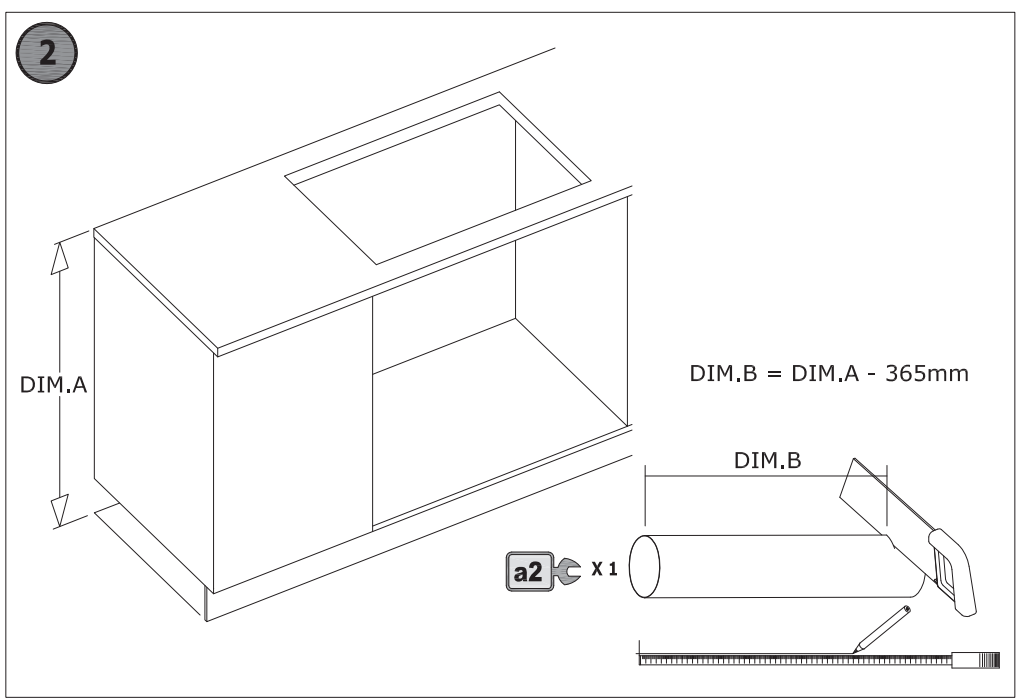
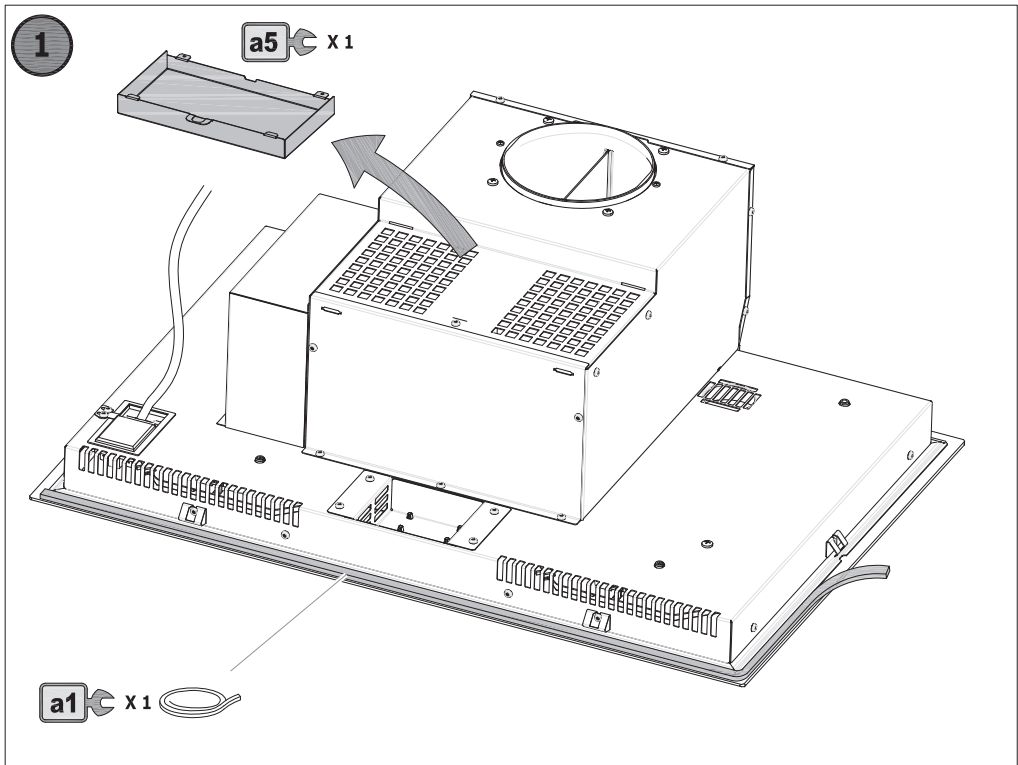

3

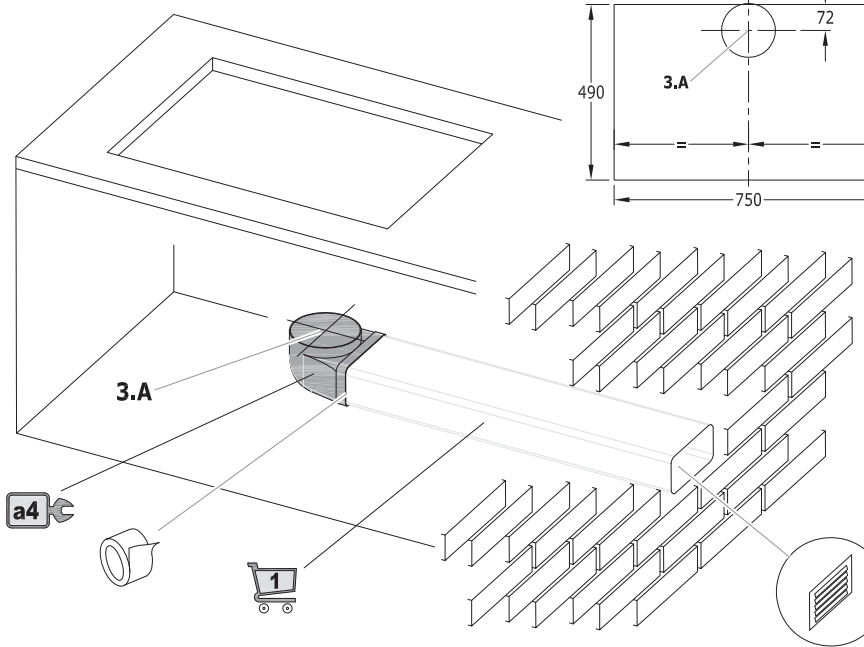
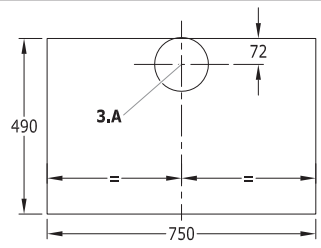

4

a3 x 1

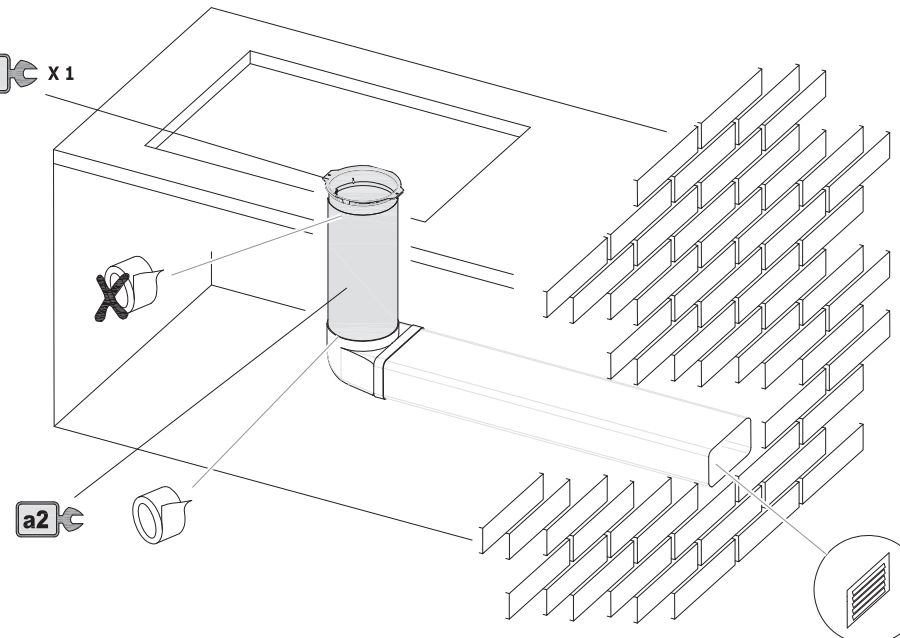

5

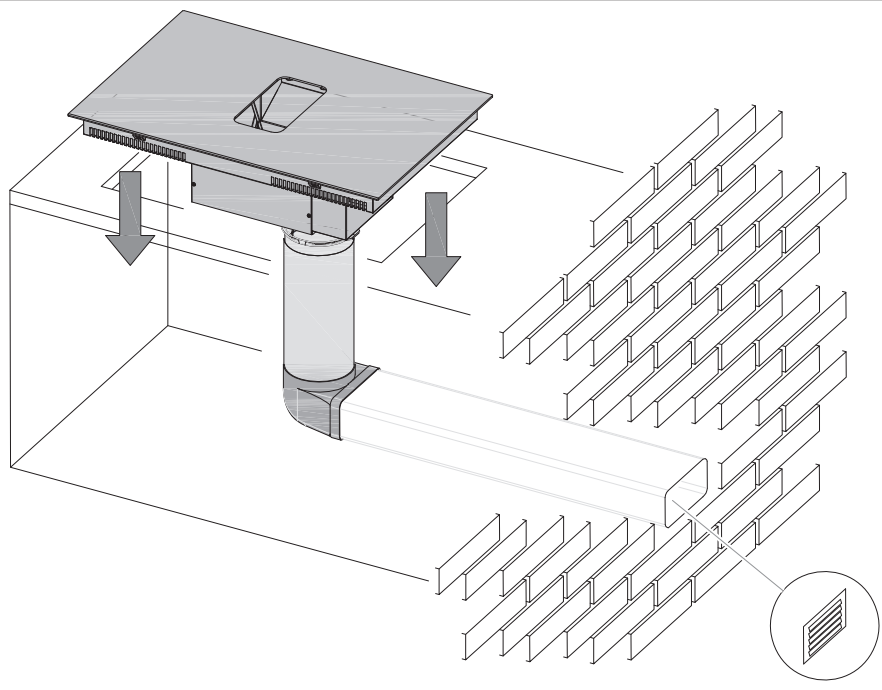

6

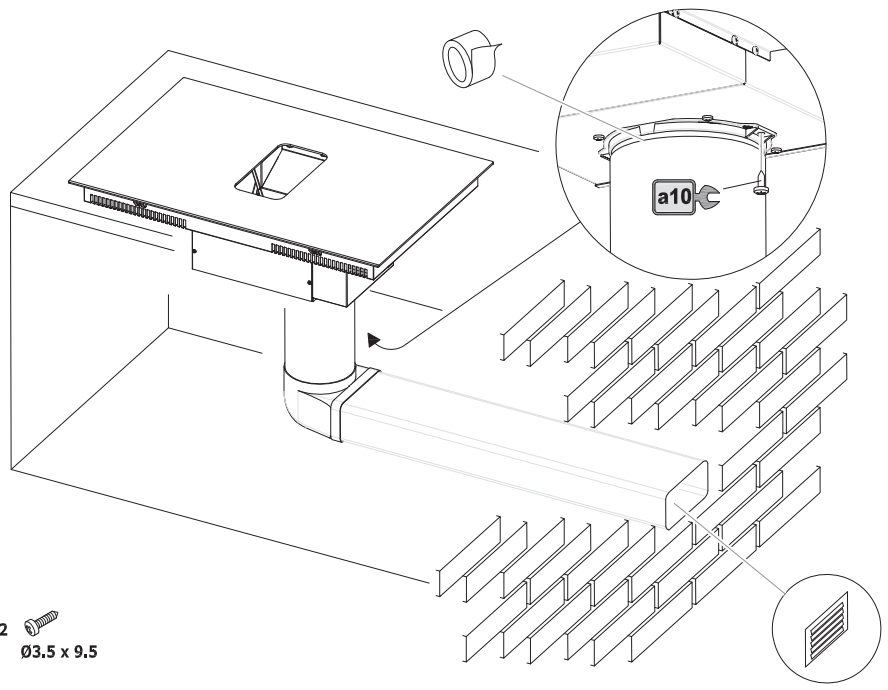
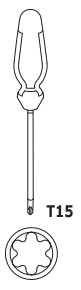

a10 x 2
Ø3,5 x 9,5

7

a5 x 1

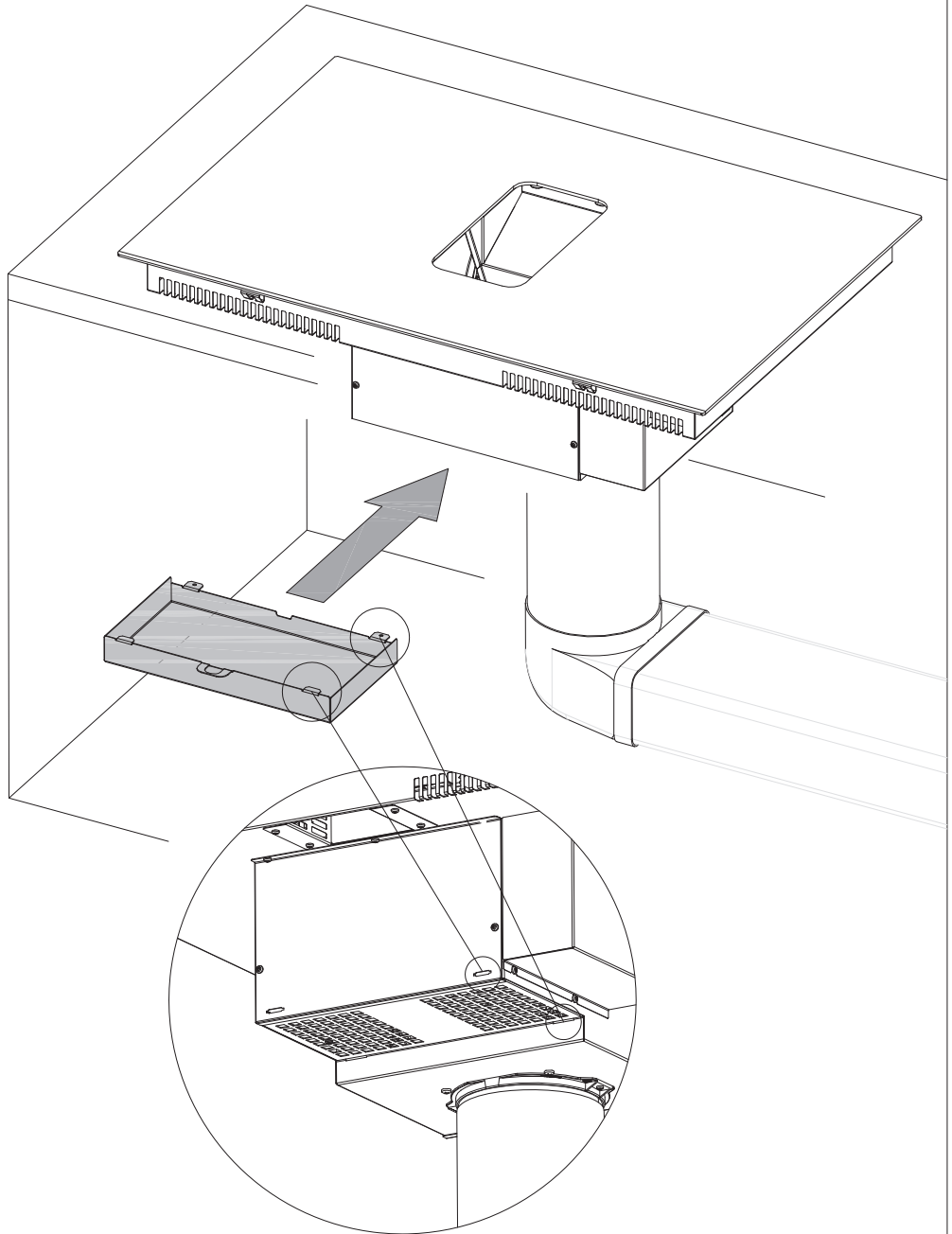
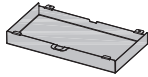

8

a6 x1

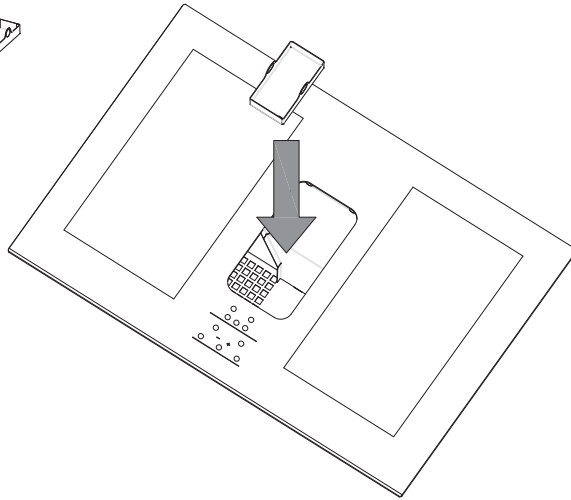

9

a8 x2

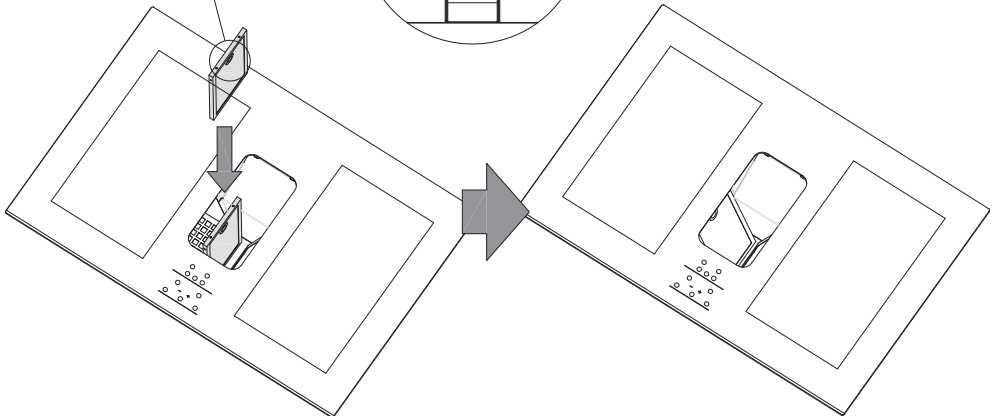
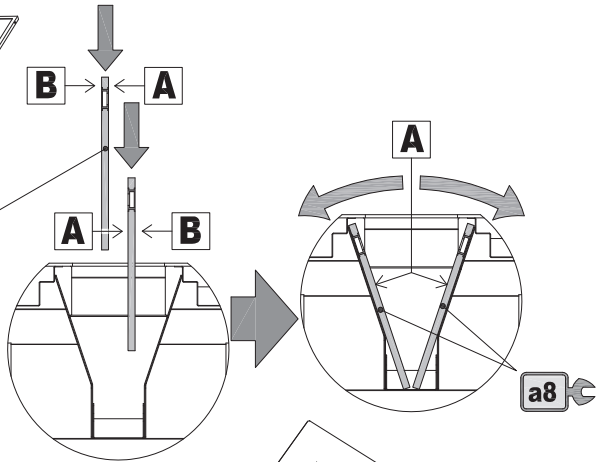
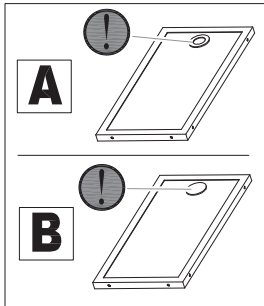

9

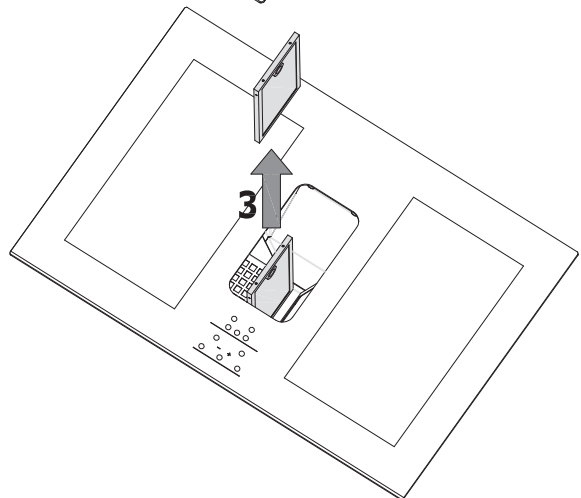
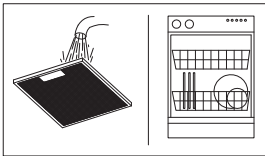
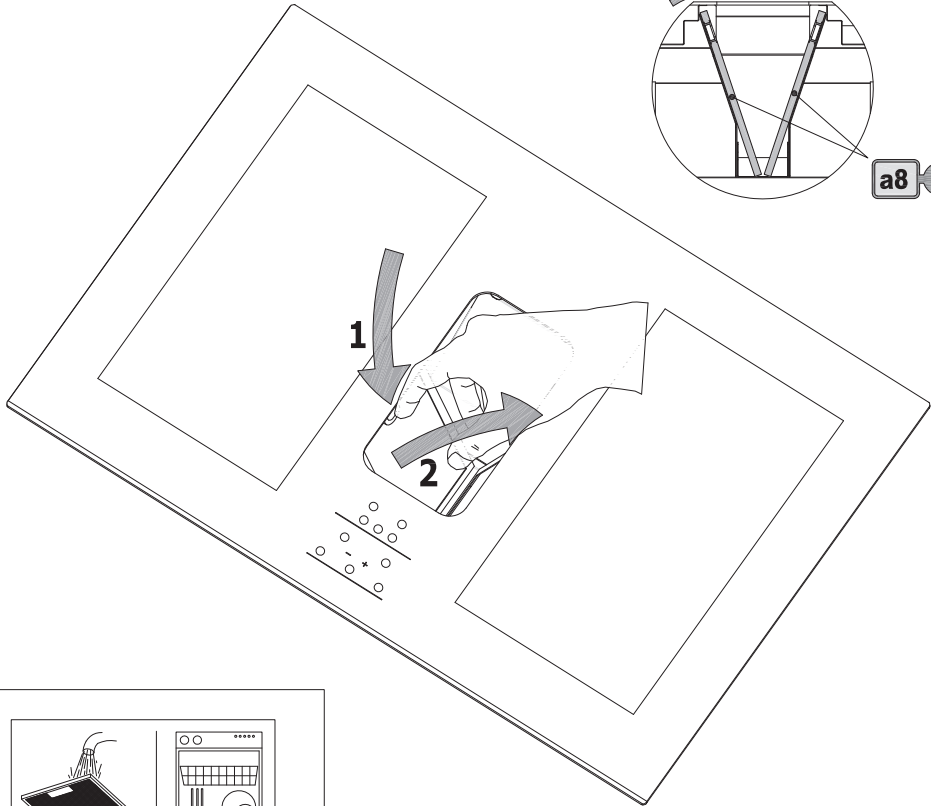
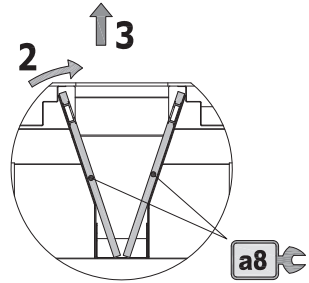

10

a9 x 1

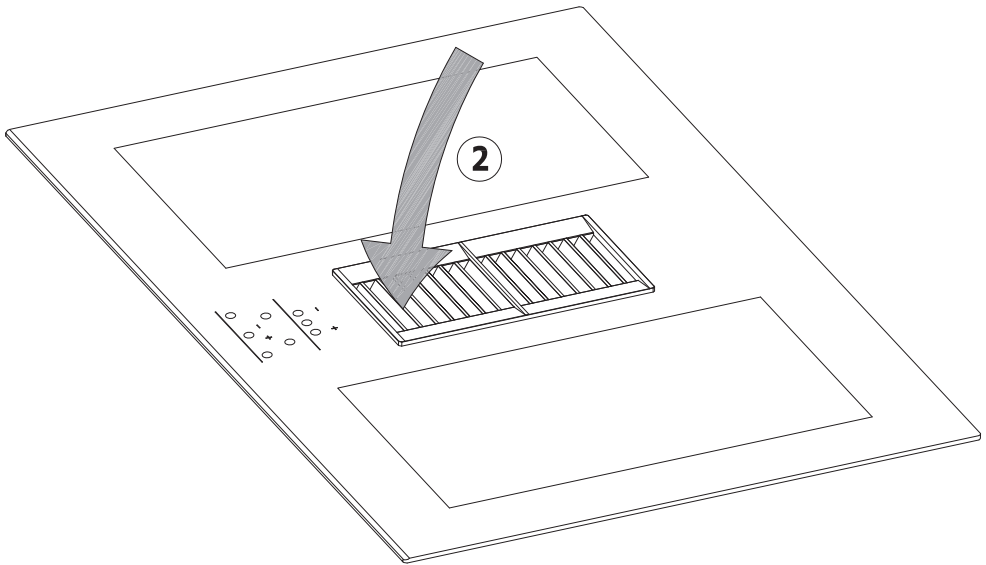
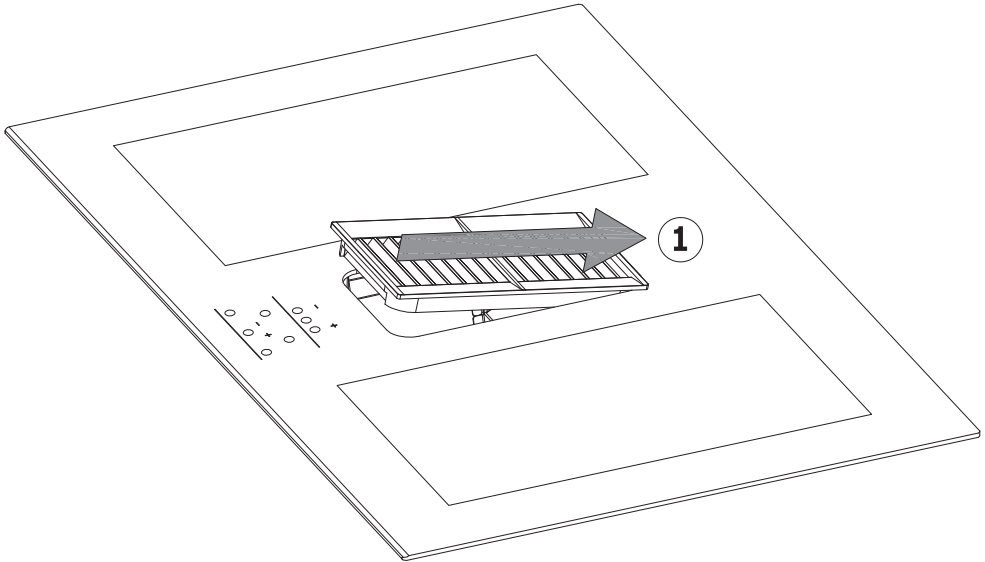

11

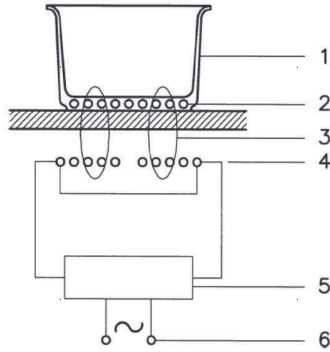

12

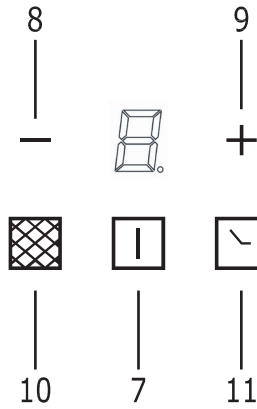

13

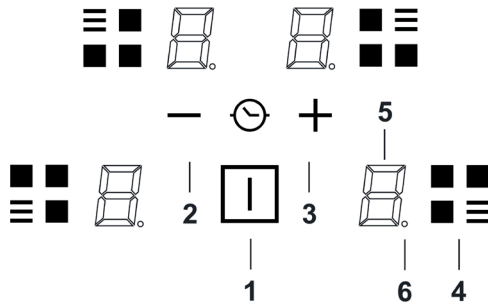

14

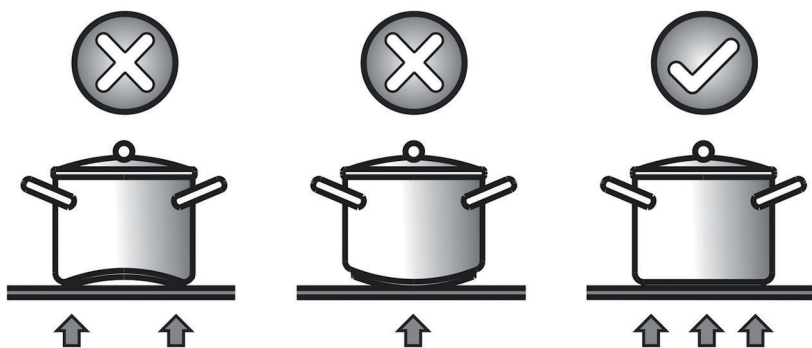

15

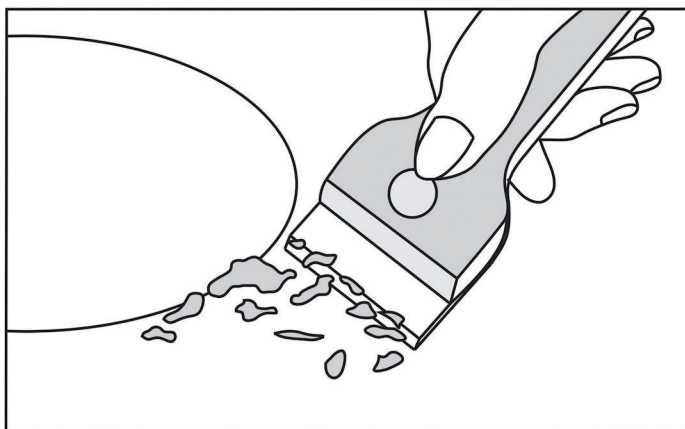

16

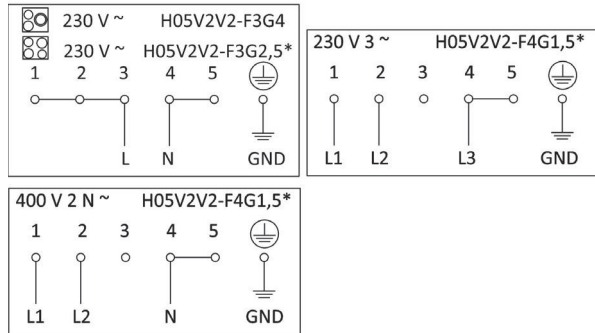

*** Considering complementary factor**

17

7-a

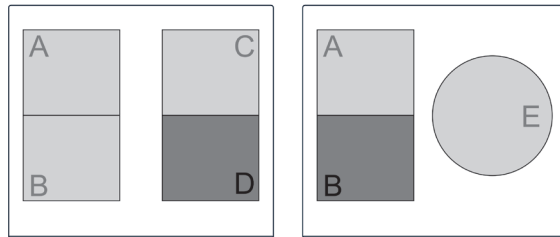

7-b

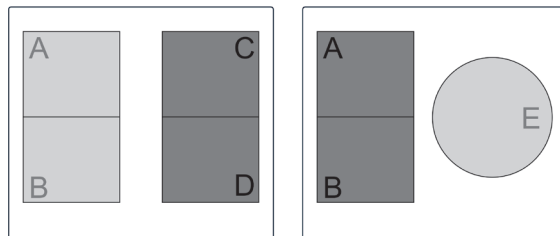

THIS APPLIANCE IS CONCEIVED FOR DOMESTIC USE ONLY. THE MANUFACTURER SHALL NOT IN ANY WAY BE HELD RESPONSIBLE FOR WHATEVER INJURIES OR DAMAGES ARE CAUSED BY INCORRECT INSTALLATION OR BY UNSUITABLE, WRONG OR ABSURD USE.

The manufacturer declares that this product meets all the essential requirements for low voltage electrical material set out in European directive 2014/35/EU and for electromagnetic compatibility as required by European directive 2014/30/EU.

PRECAUTIONS

- When the hob is in use keep all magnetizable objects away (credit cards, floppy disks, calculators and so on).
- Do not use any aluminium foil or place any foodstuffs wrapped in aluminium foil directly on the hob - do not place any metal objects such as knives, forks, spoons and lids on the hob surface as they will heat up.
- When cooking in a non-stick pan without seasoning, do not exceed 1-2 minutes' pre-heating time.
- When cooking food that may easily stick, start at a low power output level and then slowly increase while regularly stirring.
- After cooking is finished, switch off using the control provided (turn down to "0"), and do not rely on the pan sensor.
- If the surface of the hob is damaged, immediately disconnect the appliance from the mains to prevent the possibility of electric shock.
- Never use a steam cleaner to clean the hob.
- The appliance and accessible parts may be hot during operation.
- Take care to avoid touching the heating

elements.

- Children less than 8 years of age should be kept at a safe distance unless continuously supervised.
- This appliance may be used by children aged 8 or over and by persons with reduced physical, sensory or mental capabilities or lack of experience and knowledge, if they are supervised and have received suitable instructions on safe use of the appliance and understand the dangers involved. Children must not play with the appliance. User maintenance and cleaning should not be carried out by children except under constant supervision.
- Cooking with grease or oil may be dangerous and cause a fire if left unattended. NEVER try to extinguish a fire with water. Rather, disconnect the appliance and then cover the flames with a cover or sheet, for example.
- The cooking process has to be supervised. A short term cooking process has to be supervised continuously.
- Unattended cooking on a hob with fat or oil can be dangerous and may result in a fire.
- Fire hazard: do not store elements on cooking surfaces.
- Only counter top protectors designed for use with the cooking appliance and listed in the manufacturer's instructions should be used as suitable protection for the counter top incorporated in the appliance. Use of unsuitable protectors may cause accidents.
- **WARNING:** Accessible parts will become hot when in use. To avoid burns and scalds children should be kept away.

Insert in the fixed wiring a mean for disconnection from the supply mains having a contact separation in all poles that provide full disconnection under overvoltage category III conditions, in accordance with the wiring rules. The plug or omnipolar switch must be easily reached on the installed equipment.

This appliance is not intended to be used via an external timer or a remote control system. The manufacturers decline any responsibility in the event of non-compliance with what is described above and the accident prevention norms not being respected and followed.

The producer is not responsible for any failure to observe the instructions given in this manual and current safety regulations for the correct use of the equipment.

Reserves the right to make any modifications to the equipment or this manual without prior notice.

Contact our official distributor should you require technical assistance or additional information on our products.

To avoid all risk, if the power cable becomes damaged, it must only be replaced by the manufacturer, by an authorised service centre, or by a qualified electrician.

OPERATING PRINCIPLE (Fig. 11)

It exploits the electromagnetic properties of most cooking vessels. The coil (inductor) which produces the electromagnetic field is operated and controlled by the electronic circuit.

The heat is transmitted to food by the cooking vessel itself.

The cooking process takes place as described below.

- loss of heat is minimum (high efficiency)
- the system stops automatically when the vessel is removed or even just lifted from the hob
- the electronic circuit guarantees maximum flexibility and fine adjustments.

- 1 Vessel
- 2 Induced current
- 3 Magnetic field
- 4 Inductor
- 5 Electronic circuit
- 6 Power supply

User's Instructions (Fig. 2)

- 1 ON/OFF
- 2 Minus –
- 3 Plus +
- 4 Cooking zone
- 5 Setting level display
- 6 Zone selection lights

Touch panel (Fig. 12)

10. Filter clean warning display/button. Warning of the need to replace the filter – press to deactivate once the filter has been cleaned or

replaced.

8. Decrease extractor fan speed.

11. Enable and disable extractor fan timer.

Timer: the extractor fan works for 5 min. at the current speed and another 5 min. at each of the lower speeds until it stops.

12. Extractor fan speed display panel.

7.Extractor fan on and off.

9.Increase extractor fan speed.

It is advisable to let the appliance work for 15 minutes after the cooking of the food in order to remove completely the fumes.

Installation

All operations relative to installation (electric connection) should be carried out by skilled personnel in conformity with the rules in force. As for the specific instructions see part pertaining to installer.

Switching the Touch Control ON/OFF

After mains voltage is applied the control initializes for approx. 1 second before it is ready for operation.

After a reset all displays and LEDs glow for approx. 1 second. When this time is over all displays and LEDs extinguish and the control is in the stand-by mode.

Press the ON/OFF (1) button to switch the touch control on.

The cooking zone displays show a static "0".

If a cooking zone is in the "hot" status, the display shows a static "H" instead of "0". The bottom right dot is blinking in 1 second intervals on all cooking zone displays to indicate that no cooking zone is selected at the moment.

After switching-ON the electronic control remains activated for 20 seconds. If no cooking zone or timer selection follows within this period of time, the electronic control automatically switches back into the stand-by-mode. The control can only be switched-ON if it identifies the ON/OFF key alone being operated. Should it recognize key activation other than that, the control remains in the standby-mode.

If the child safety feature is active when switching on, all cooking zones show "L", (LOCKED). If the cooking zones are in a "hot" status, the display shows "L" and "H" in alternation. When the Touch Control is ON it can be switched- OFF at any time by operating the ON/OFF key. This is also valid if the control has been locked (activated child safety feature).

The ON/OFF key has always priority in the switch-OFF function.

Automatic switch-OFF

When the control is ON it automatically switches-OFF after 20 seconds if no cooking zone or select key has been operated within this period of time. If case of a cooking zone selection, the automatic switch-OFF time is composed of 10 seconds deselection time for a cooking zone at setting"0" and 10 seconds switch-OFF time.

Switching a cooking zone ON and OFF

First place the pan in the chosen cooking zone. If the pan is not present the system cannot be switched on the correspondent zone.



If the touch control is switched on, the cooking zone can be selected by pressing the button (4) of the corresponding zone.

The display (5) of the zone selected lights up, while the remaining displays are dimmed. If the cooking zone is "hot", "H" and "0" are alternately displayed.

Press the PLUS (3) or MINUS (2) button to select a setting and the zone will begin to heat up.

Once the cooking zone has been selected, the setting can be

selected by keeping the PLUS (3) button pressed down. The setting begins at level 1 and increases by 1 level every 0.4 seconds. When setting "9" is reached, the setting will not be changed further. If the setting level has been selected using the MINUS (2) button, the start level is "9" (maximum level). Keep the button pressed down to lower the active level by 1 every 0.4 seconds. When setting "0" is reached, there will be no further setting changed. The setting can only be changed by pressing the MINUS (2) or PLUS (3) button again.

Switching a cooking zone off

Select the zone to be switched off using the corresponding button (4). The display (5) of the zone selected lights up, while the remaining displays are dimmed. Press the Cooking zone (4) and MINUS (2) buttons at the same time and the setting level of the zone is changed to 0. Alternatively, the MINUS button (2) can be used to reduce the setting level to 0.

If a cooking zone is "hot", "H" and "0" will be alternately displayed.

Switching-OFF all cooking zones

Immediate switching-OFF of all cooking zones can be achieved anytime by means of the ON/OFF key. In the standby-mode an "H" appears on all cooking zones which are "hot". All other cooking zone displays are not illuminated.

Wattage settings

The output of the cooking zones can be set in 9 steps which are indicated by the figures "1" thru "9" by means of LED sevensegment-displays.

In the cooking zone located on the front left, when selecting the power level 9 and after 30 minutes operating, the power will decrease slightly for safety reasons. In case more power is required, select the boost level ("P")

Cooking Zones

There are several possible cooking zone combinations:

Single Cooking Zone (Fig. 7-a)

Depending on the model, there are 3 or 4 single cooking zones (A, B, C, D, E) which can function independently.

Minimum diameter of the pan base to ensure optimal detection:

Zones A, B, C, D: 12 cm / Zone E: 14.5 cm

Dual Cooking Zone (Fig. 7-b)

There is a further option of two single cooking zones operating together as if they were a single zone. The possible cooking zone combinations are A+B or C+D. This function is enabled by simultaneously pressing the selection keys "8" on both the zones to be combined. The following symbol will then be shown on display "8" of the rear area:



Display "8" located on the front area will indicate the power level selected for the combined zone.

This function makes it possible to obtain a rectangular cooking zone, particularly suited to rectangular or oval-shaped pans.

If you are using a round pan, the minimum diameter of the base should be 20 cm in order to ensure optimal detection.

Boost function

After selection of a respective cooking zone, the boost function can be activated by selecting the power level 9 and then pressing PLUS (3) button. By means of this function certain cooking zones are enabled to receive power over the nominal (the number of boostable cooking zone depends on the power available on a partial modules which is to be less than total hob power). If the desired cooking zone has the capacity to activate the booster, the display shows a "P" symbol. In case the available power is not enough the cooking stage display flashes for 3 seconds on the cooking zone which needs to be reduced and which requires automatic adjustment.

The boosting time is limited to 5 min to protect cooking utensils. After the booster is switched off automatically, the cooking zone continues operation on power level "9". The booster can be reactivated after

some minutes.

In case that the pan is removed from the cooking zone during boosting, the boosting function remains active and boosting time continues.

The power management is based on the principle that the last entry is requested by the induction as top priority. That means that previous actions and settings also made for the other cooking zones are reversed automatically, if necessary.

- If induction identifies the necessity of reducing power at a cooking zone, the selected cooking stage flashes on that cooking zone providing a correction period of 3 sec before the power is reduced automatically to a minimum cooking stage.

- If the setting is adjusted within the correction period, the power management checks the settings again. Should a new setting lead to further power reduction, the correction period starts again.

- If no automatic correction needs being made to the cooking zone setting, the flashing stops immediately and the original value remains as a steady display indication. Should the situation change again on the power reduced cooking zone, no automatic power increase is effected.

NOTE:

When selecting the Booster function on any of the rear areas (left or right), the front area located on the same side will automatically switch off (if it was already switched on) in order to focus all the power on the rear area. This allows you to benefit from an extra powerful Booster.

However, when selecting the Booster function on any of the front areas (left or right), the rear area located on the same side may be operated up to power level 8, as it will not require as much energy input.

Residual heat indicator

It is meant to indicate to the user that the glass ceramic has a dangerous touch temperature in the circumference of a cooking zone. The temperature will be determined following a mathematical model and the remaining residual heat will be indicated by means of "H" on the corresponding 7-segment display.

Heating-up and cooling down will be calculated dependent on:

- the selected setting („0" to „9")
- the ON/OFF time.

After switching-OFF the cooking zone the respective display shows "H" until the assigned cooking zone temperature is mathematically in a uncritical level. (≤ 60°C).

Automatic Switch-off (Operating Time Limitation)

For each activated cooking zone a max. operating time is defined. The max. operating time is depending on the selected cooking stage. After the expiration of the max. operating time the cooking zone is automatically switched off.

Each actuation of the cooking zone status (changing the cooking level etc.) resets the count-down timer to the initial starting value.

Timer settings takes priority vs. operating time limitations for high cooking stage setting.

Protection against unintended switching-ON

- If the electronic control realizes a continuous operation of keys for approx. 10 seconds, it switches OFF automatically. The control sends out an audible failure signal for 10 seconds, so that the user can remove the object which has been mistakenly placed onto the operation surface. The displays show the failure code " E R 0 3 " .

If the failure carries on for more than 10 seconds, only the code " E R 0 3 " will be displayed as long as the failure will be recognized by the electronic control. If the cooking zone is in the "hot" status, "H" will appear on the display in alteration with the failure notice.

- If no cooking zone will be activated within 20 seconds after switching-ON by means of the Power-key, the control switches

back from the ON-condition into the stand-by-mode.

- When the control is switched- ON the ON/OFF-key has priority over all other keys, so that the control can be switched-OFF anytime, even in case of multiple or continuous operation of keys.
- In the stand-by mode a continuous operation will not be signaled. However, before the electronic control can be switched-ON again, it has to recognize that all keys are not operated.

Key lock (child safety feature)

◇ Child safety feature:

Key lock:

After switching-ON the control the child safety feature can be activated. To achieve this it is necessary to simultaneously operate the front right cooking zone- select-key and the MINUS-key and then press the front right cooking-zone-select key again. There will be an "L", meaning LOCKED (child safety feature against unintended switching-ON). If a cooking zone is in the "hot" condition, "L" and "H" will be displayed in alternation.

This course of operation has to take place within a period of 10 seconds, no other key than described above may be operated. Otherwise the input will be interrupted because of incompleteness, the cook top will not be locked then.

The electronic control remains in a locked condition until it gets unlocked, even if the control has been switched-OFF and -ON in the meantime. Also a reset of the control (after a voltage drop) does not cancel the key lock.

Unlocking for cooking purposes: :

To unlock and operate the control it is required to operate the front right cooking- zone select- key and the MINUS-key simultaneously. "L" (LOCKED) in the display extinguishes and all cooking zones show "0" with a blinking dot. Should a cooking zone be "hot", "H" is displayed instead of the static "0". After switching- OFF the control, the child safety feature is active again.

Canceling the key lock:

After switching-ON the control the child safety feature can be deactivated. Here it is necessary to simultaneously operate the front right cooking-zone-select key and the MINUS-key and then operate the MINUS-key alone. If all steps have been carried out in the right order within 10 seconds the key lock gets cancelled and the control is OFF. Otherwise the input will be considered incomplete, the control remains locked and switches-OFF after 20 seconds.

After a renewed switching-ON by means of the ON/OFF key all displays show „0“, the display dots are blinking and the control is ready for cooking. If a cooking zone is in "hot" mode, "0" and "H" will be alternately displayed.

Audible signal (buzzer)

While the control is in operation the following activities will be signaled by means of a buzzer:

- normal key activation with a short sound signal.
- continuous operation of keys over a longer period of time (10 seconds) with a longer, intermittent sound signal.

Timer function (optional)

The timer function is realized in two versions:

- Stand-alone timer 1..99 min: sound signal when the time is over (= minute minder). This function is only available when the cooktop is not in operation, i.e. when there is no cooking.
- Cooking zone timer 1..99 min: sound signal when the time is over, four cooking zones can be programmed independently.

Timer as minute minder (stand-alone):

- If the control is ON and no cooking zone selected, the stand-alone-timer can be used by simultaneously operating MINUS (2) and PLUS (3) keys.
- Adjustment range (0-99min), it can be set in 1-minute steps with any key, starting at 1 up to 99 (end stop) with the minus-key starting

at 99 down to 0 (end stop)

- Continuous activation of the plusor minus-key results in a dynamic increase of the adjustment speed up to maximum value without sound signal.
- when the plus- or minus key is released in the meantime, the adjustment speed starts again from a (low) initial value.
- adjustment can be made with a continuously activated plus- or minus-key or by tip-operation (with sound signal) After the timer is set the time runs down according to the adjustment. When the time is over there is a sound signal and the timer display blinks.

The sound signal will be stopped

- automatically after 2 minutes and/or

· by operating any key.

Then the blinking of the timer display stops and the display extinguishes.

Switching-OFF/changing the timer

- The timer can be changed or switched-off anytime by simultaneously operating MINUS (2) and PLUS (3) keys. (with sound signal). The timer will be switched off by counting down to "0" with the minus-key.

For 6 seconds the timer display remains at "0" before it will be switched-off.

- If the control will be switched- ON by means of the Power-key, the stand-alone timer will be switched-off also.

Timer programming on cooking zones

When the control is switched- ON an independent timer can be programmed for every cooking zone.

- By selecting a cooking zone with the cooking-zone-selectkey (4), then selecting the setting and, finally, operating MINUS (2) and PLUS (3) keys simultaneously, the timer can be programmed as a switch-off function for a cooking zone.
- During timer programming, the pilot light (6) of the selected cooking zone blinks.
- When the timer has run down, there is a sound signal and the timer display shows "00" statically, the assigned cooking zone timer LED blinks. The programmed cooking zone will be cut off and „H" will be displayed if the coking zone is hot, otherwise a stroke will show in the cooking zone display.

The sound signal and the blinking of the timer LED will be stopped

- automatically after 2 minutes

· by operating any key.

The timer display extinguishes.

- The basic behaviour follows the description of the "minute minder" (stand-alone-timer).

Cooking vessels (Fig. 14)

- a magnet-attracting vessel may be a suitable vessel for induction cooking
- prefer vessels which are especially declared to be suitable for induction cooking
- flat- and thickbottomed vessels
- a vessel with the same diameter as zones ensures the maximum exploitation of power
- a smaller vessel reduces power exploitation, but does not cause any energy loss We would anyhow not recommend the use of vessels with diameters smaller than 10 cm.
- stainless-steel vessels with multi-layer or ferritic stainless-steel bottoms when specifically suited for induction cooking
- cast-iron preferably enamel-bottomed vessels to avoid scratching the pyroceram surface
- we do not recommend the use of any glass, ceramic, earthenware, aluminium, copper or non-magnetic (austenitic) stainlesssteel vessels.

Maintenance (Fig. 7,8,9,10,15)

By means of a scraper immediately remove any aluminium foil bits, food spills, grease splashes, sugar marks and other high sugarcontent food from the surface in order to avoid damaging the hob.

Subsequently clean the surface with some towel and appropriate product, rinse with water and dry by means of a clean cloth. Under no circumstance should sponges or abrasive cloths be used; also avoid using aggressive chemical detergents such as oven sprays and spot removers.

Grease filters: to avoid fires, clean thoroughly once a month or whenever the display pilot light indicates as such. To do so, remove the filters and wash with hot water and detergent. If using a dishwasher, position the filters vertically to prevent solid remains from depositing on them. do not use polish to clean or shine

Activated charcoal filters: replace the every 3 months.

Important: increase the filter cleaning/replacement frequency if the hood is used for more than 2 hours a day. Always use genuine filters from the manufacturer.

Installer's Instructions**Installation (Fig. P1, P2, P3)**

These Instructions are for the qualified technician, as a guide to installation, adjustment and maintenance, according to the laws and standards in force. These operations must always be carried out when the appliance has been disconnected from the electric system.

Positioning (Fig. 1,2,3,4,5,6)

The fixture is especially designed for fitting into a work-top as shown in the corresponding figure.

Place the supplied sealing agent along the hob perimeter.

It's forbidden to install the hob over an oven.

Electrical connection (Fig. 16)

Prior to carrying out the electrical connection, please ensure that:

- the plant characteristics are such as to follow what is indicated on the matrix plate placed at the bottom of the working area;
- that the plant is fitted with an efficient earth connection, following the standards and law provisions in force.

The earth connection is compulsory in terms of the law.

Should there be no cable and/or plug on the equipment, use suitable absorption material for the working temperature as well, as indicated on the matrix plate. Under no circumstance must the cable reach a temperature above 50°C of the ambient temperature.



**Apelson Appliances Uk Ltd
Unit 3 Normandy Landings
Pope Street
Castleford
WF6 2AG**

60818430.26.11.2018